

WIRING AND CALIBRATION

Transmitter Options W,X,Y & Z

Table of Contents

	Page
1. Installation and Wiring	1
1.1 General	1
1.2 Precautions	1
2. Interfacing the frequency output.....	2
3. Interfacing the limit switches	2
4. Field Calibration (4-20 mA dc)	3
5. Field Calibration (0-1000 Hz)	4

Figures

Figure 1 Terminal Strip	1
Figure 2 K-factor Table.....	2
Figure 3 Transmitter Connections	3
Figure 4 Transmitter Board	4

1

Installation & Wiring

1.1 General

The transmitter board is fitted inside the enclosure of either the threaded or wafer style flowmeter. Option W provides a 4-20 mA dc, option Y provides a 0-1000 Hz frequency, option X provides set point switching and option Z combines W, X & Y.

The position of the gear lever is detected using a pair of magnets mounted on the lever and a solid state Hall effect sensor mounted on the circuit board. The output of the transmitter is linear with flow. The transmitter is powered by an external 24 volt dc power supply provided by the user. A rated capacity of 100 mA is required to power all options.

1.2 Precautions

The power supply used to power the transmitter **MUST BE ISOLATED**. This means that the power supply ground and the input signal grounds must **NOT** be common. Some batch controllers and counters have auxiliary power supplies which are not isolated. Use of these non-isolated power supplies will cause a failure of the power supply and/or the transmitter board.

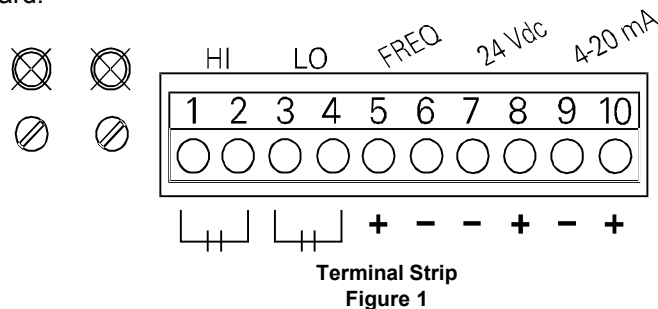

Important. Do not connect terminals 7 and 9 together. Damage will result. The installation must be 4-wire. One pair of wires supplies 24 Vdc to pins 7 and 8 and one pair carries the 4-20 mA signal to the peripherals.

2

Interfacing the frequency output

2.1 Frequency output interfacing

The frequency output is always factory set to 1000 Hz at full scale flow. To count total flow from the frequency output, it is necessary to scale this output. The scaling factor, K is derived as follows:

$$K = \frac{1000 \text{ pulses / sec} \times 60 \text{ sec / min}}{\text{full scale flow rate (units / min)}}$$

The table below was computed from the above equation and is presented for your convenience.

Scale	K-factor	Scale	K-factor	Scale	K-factor	Scale	K-factor
1	60000	20	3000	120	500	600	100
2	30000	25	2400	150	400	800	75
3	20000	30	2000	200	300	1000	60
4	15000	40	1500	240	250	2000	30
6	10000	50	1200	250	240	3000	20
8	7500	60	1000	300	200	4000	15
10	6000	80	750	400	150	6000	10
15	4000	100	600	500	120		

K-factor Table
Figure 2

The frequency output is a square wave with an amplitude of 5 Vp (into a 10 K ohm or greater impedance). The on time is controlled at 270 microseconds \pm 30 microseconds.

The frequency output falls to 0 Hz. whenever the flow rate falls below approximately 20% F.S.

Important. Do not connect terminals 6 and 7 together. Damage will result. The installation must be 4 wire. One pair of wires supplies 24 V dc to pins 7 and 8 and one pair of wires carries the frequency signal to the peripherals. If the current option is fitted, an additional pair of wires is required to carry the current output.

3

Interfacing the limit switches

3.1 Limit switch interfacing

Power is required to the transmitter board in order for the limit switches to operate. When no power is available, both switches are open and do not close regardless of the flow rate.

- LO Switch When power is applied at zero flow, the LO switch closes. As flow increases to the set point, the LO switch opens.
- HI Switch When power is applied at zero flow, the HI switch remains open. As flow increases to the set point, the HI switch closes.

Each switch can be independently set to anywhere in the range. Therefore, the terminology of HI or LO is purely arbitrary. The user can achieve the desired fail safe system wiring by reversing the convention if necessary. As a result the relays can be wired to suit most system or alarm applications.

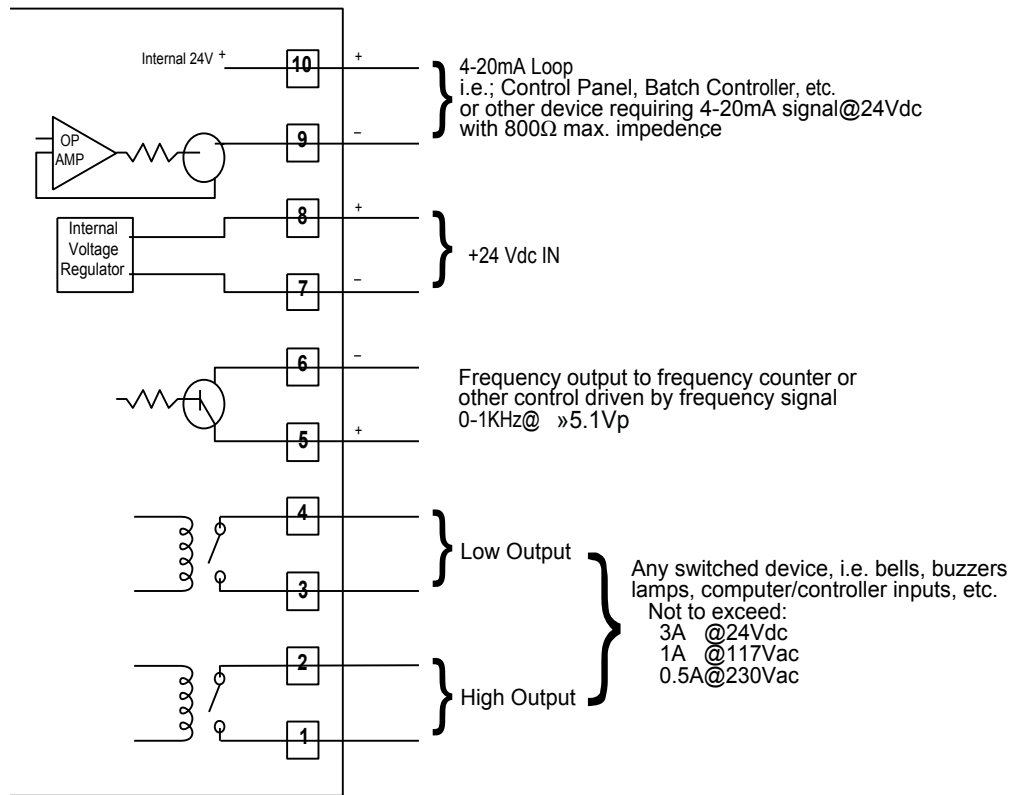

Transmitter Connections
Figure 3

4

Field Calibration (4-20 mA dc)

4.1 Test equipment

Fluke 9600A digital multimeter or equivalent
Non-metallic screwdriver

4.2 Setup

Remove the back cover plate to gain access to the adjustment pots and the mechanical parts of the flowmeter. (Refer to the Installation, Operation and Maintenance Manual for the Series 7000 and Series 8000 Flo-Gage if necessary.) Remove the housing lens to gain access to the pointer. Make all mechanical adjustments before proceeding. **DO NOT APPLY POWER UNTIL ALL CONNECTIONS ARE MADE.**

Connect 24 V dc power supply positive to terminal 8 and negative to terminal 7. Set multimeter to milliamp scale and connect to terminal 9 and 10. Turn power on. Observe current output reading.

4

Field Calibration (4-20 mA dc) (Continued)

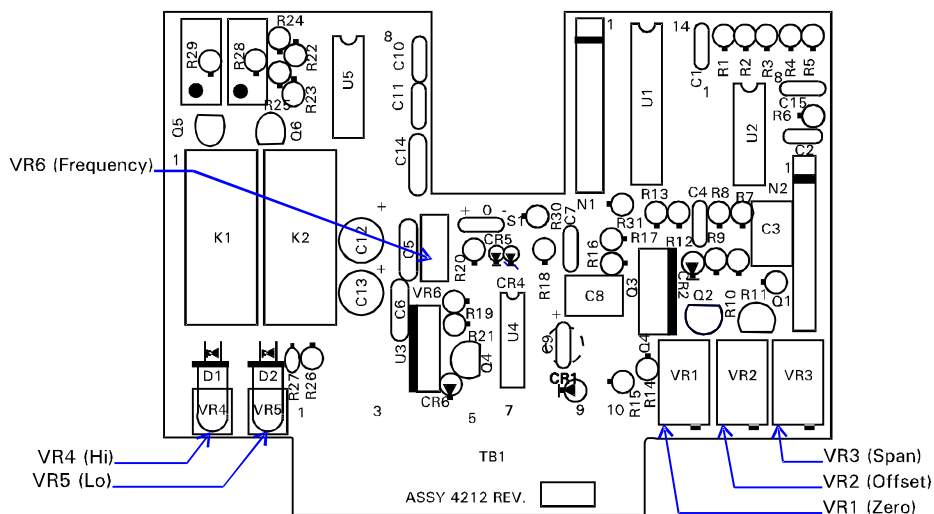

Transmitter Board
Figure 4

4.3 Adjustment pot location

Pots VR1, VR2 and VR3 are located just to the right of the terminal strip when viewing the meter from the rear. VR1 is adjacent to terminal 10, VR2 is the center pot and VR3 is the rightmost. See Figure 4.

4.4 Calibration

Note: The easiest way to set the pointer for calibration of the transmitter is with the vertical lever. By manipulating this lever, the pointer can be driven up/down scale to the desired location, simulating the flowrate at any given point. (Take care not to flex this lever front to back as calibration will be affected.)

Adjust zero pot VR1 fully CCW. Adjust 4 mA output pot VR2 to 4.00 mA. Set pointer to 30%. Adjust zero pot VR1 to 8.8 mA ± 0.2 mA. Set pointer to 95%. Adjust span pot VR3 to 19.2 mA ± 0.2 mA. Repeat zero (VR1) and span (VR3) adjustments until both adjust within specifications.

5

Field calibration 0-1000 Hz

5.1 Field Calibration

If the transmitter is fitted with current output, adjust current output first. With the pointer at 95% F.S. set VR6 span pot for 950 Hz ± 30 Hz. If current output is not fitted, the meter *MUST* be returned to the factory for calibration.